

Finger Pull Cutters

TCT Finger Pull

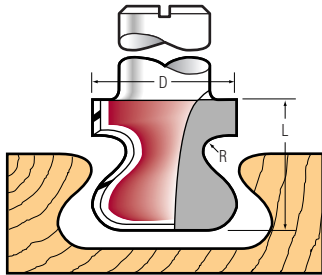

FPC19

n. max
24,000



BG-TEST
145-001

For solid handles and pulls on kitchen and wall unit doors, with bottom cut for better finish and plunging.

Order Ref. No.	Dmm	Lmm	Rmm	1/4"	8mm	Shank 3/8"	12mm	1/2"
FPC19	19	19	2	£78.00	£78.00	£78.00	£78.00	£78.00

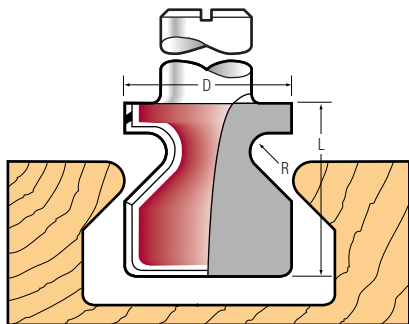

FPC22

n. max
24,000



BG-TEST
145-001

A variation of the FPC19 giving a square bottom and undercut.

Order Ref. No.	Dmm	Lmm	Rmm	8mm	Shank 12mm	1/2"
FPC22	22	22	2.5	£85.00	£85.00	£85.00

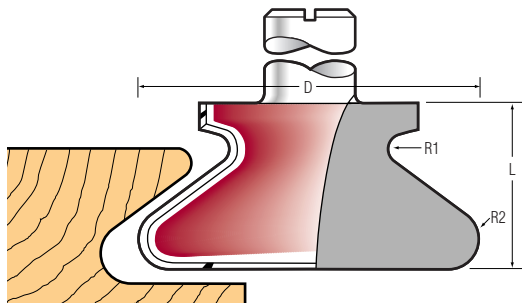

SFPC45

n. max
18,000



BG-TEST
145-001

This shallow finger pull cutter has a smaller radius but longer on projection.

Order Ref. No.	Dmm	Lmm	R1mm	R2mm	Undercut Depthmm	Shank 12mm	1/2"
SFPC45	45	22	3	4	12	£85.00	£85.00

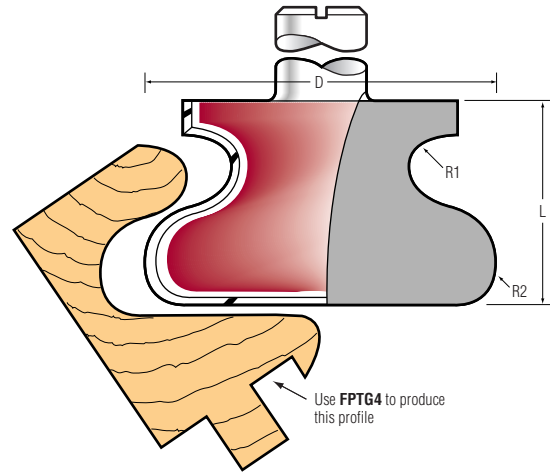

FPC47

n. max
18,000



BG-TEST
145-001

Used on its own to produce shallow undercut mouldings or together with FPTG4, see next, for machining of traditional finger pull sections. An inexpensive alternative to complicated profile cutter blocks on a moulding machine.

Order Ref. No.	Dmm	Lmm	R1mm	R2mm	Shank 12mm	1/2"
FPC38	38	23	2	6.3	£89.00	£89.00
FPC47	47	28.7	3.5	6.3	£109.00	£109.00

TCT Finger Pull & Groover Set

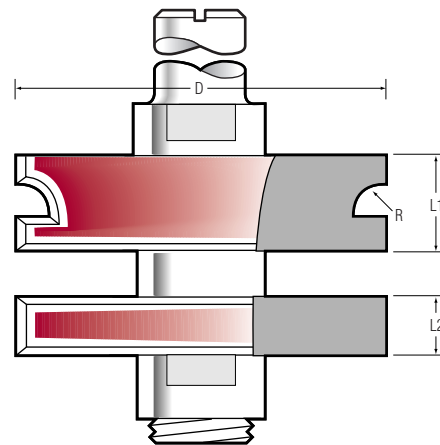

FPTG4

n. max
18,000



Supplied as a complete set including shaping cutter, 2 groovers, spacer and arbor, the FPTG4 fulfills the need to produce intricate finger pull sections using a router. Use together with FPC47 to complete section.

Fixed head machines only - not on portables.

Order Ref. No.	Dmm	L1mm	L2mm	Rmm	Groover Width mm	Shank 12mm	1/2"
FPTG4	50	13	8	4	6+8	£154.00	£154.00

35

Premier Router Cutters