

# Straights

Profiling and edging

Grooving and slotting

Rebating and recessing

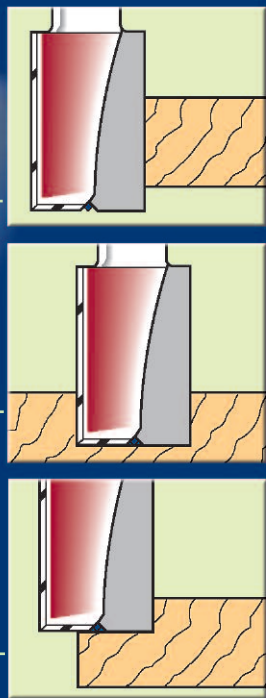

## TCT Double Flute with Centre Point

The most complete range of premier TCT double flute straight fractional & metric cutting diameter router cutters for all types of routing machines.

These are hallmark of Titman quality, strength and performance. Newly developed tungsten carbides have increased their longevity making them the most cost effective in the market today. Independent tests prove them to out perform other cutters in metres cut. They are designed to the BG test which only applies to cutters over 15.9mm diameter. Cutters below 15.9mm diameter do not require a BG test no.

\* = Solid carbide insert. \* = Solid carbide. SS = Short shank.

n.max  
24,000



BG-TEST  
145-002

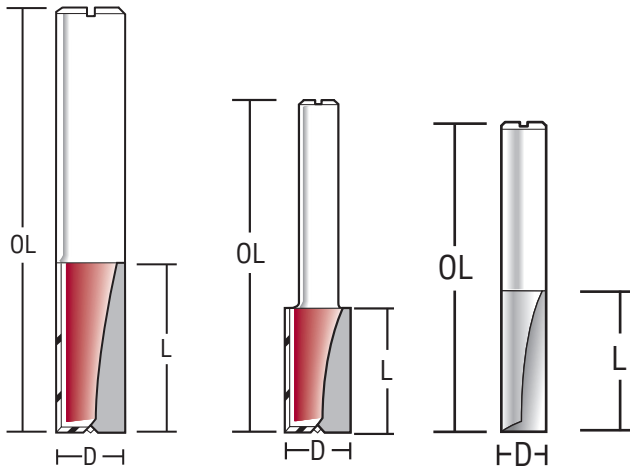

Order Ref. No.	D"	L"	OLmm	1/4"	Shank 8mm	3/8"	1/2"
H18	1/8	3/8		£15.00*	-	£20.00*	£15.00*
P964	9/64	7/16		£20.00*	-	-	-
P1164	11/64	7/16		£20.00*	-	-	-
P316	3/16	1/2		£15.00*	-	£20.00*	-
H316	3/16	1/2	63	-	-	-	£20.00*
P31658	3/16	5/8		£20.00*	-	£20.00*	-
P14716	1/4	7/16		£18.00	-	-	-
S14716	1/4	7/16		£15.00	-	-	-
H14	1/4	3/4		£22.00*	-	£22.00*	£23.00*
H141	1/4	1		£25.00*	-	£25.00*	£26.00*
S14118	1/4	1.1/8		£26.00*	-	-	-
H516	5/16	3/4		£20.00	-	£20.00	£20.00
H5161	5/16	1		£23.00	-	£23.00	£26.00
H38	3/8	3/4		£20.00	-	£20.00	£21.00

Order Ref. No.	D"	L"	OLmm	Shank					
				1/4"	8mm	3/8"	12mm	1/2"	9/16"
H381	3/8	1		£20.00	£21.00	£21.00	-	£18.00	-
S381	3/8	1		-	-	£43.00*	-	-	-
H3814	3/8	1.1/4		£23.00	-	-	-	£23.00	-
P3812	3/8	1.1/2		-	-	£31.00	-	-	-
P716	7/16	3/4		£23.00	-	£23.00	-	-	-
H71614	7/16	1.1/4		-	-	-	-	£27.00	-
P12	1/2	3/4		£18.00	-	£20.00	-	-	-
H1234	1/2	3/4		-	-	-	-	£20.00	-
H121	1/2	1	57	£18.00	-	£21.00	-	£19.00	-
H12	1/2	1.1/4		£23.00	-	£27.00	-	£19.00	-
S12	1/2	1.1/4		-	-	-	-	£57.00*	-
H1212	1/2	1.1/2		-	-	£25.00	-	£26.00	-
H122SS	1/2	2	84	-	-	-	-	£28.00	-
H122	1/2	2	99	-	-	£25.00	-	£28.00	-
H12212	1/2	2.1/2	105	-	-	-	-	£32.00	-
H12212L	1/2	2.1/2	130	-	-	-	-	£34.00	-
H12212L1	1/2	2.1/2	150	-	-	-	-	£43.00	-
H12212L2	1/2	2.1/2	170	-	-	-	-	£49.00	-
H916	9/16	1.1/4		£24.00	-	-	-	£24.00	-
P58	5/8	3/4	50	£23.00	£23.00	£23.00	-	£23.00	-
P581	5/8	1		£30.00	-	£30.00	-	£30.00	-
H58	5/8	1.1/4		-	-	£25.00	-	£25.00	-
H5812	5/8	1.1/2		-	-	£32.00	-	£32.00	-
H582	5/8	2		-	-	-	-	£36.00	£36.00
H58214	5/8	2.1/4		-	-	-	-	£39.00	£39.00
H58212	5/8	2.1/2		-	-	-	-	£40.00	-
P34	3/4	3/4		£25.00	-	£25.00	-	-	-
P341	3/4	1		£27.00	£27.00	£27.00	-	-	-
H34	3/4	1.1/4		-	-	-	-	£28.00	-
H3412	3/4	1.1/2		-	-	-	-	£33.00	-
H342	3/4	2		-	-	-	-	£36.00	-
H34212	3/4	2.1/2		-	-	-	-	£42.00	-
H1316	13/16	1.1/4		-	-	-	-	£35.00	-
P78	7/8	3/4		£24.00	-	£24.00	-	-	-
H78	7/8	1.1/4		-	-	£32.00	-	£32.00	-
P134	1	3/4		£29.00	-	£29.00	-	£29.00	-
H1	1	1		£31.00	-	£31.00	-	£32.00	-
H112	1	1.1/2	79	-	-	-	-	£40.00	-
H12L	1	2		-	-	-	-	£55.00	-
H11614	1.1/16	1.1/4		-	-	-	-	£43.00	-
H118	1.1/8	1		-	-	-	-	£44.00	-
H114	1.1/4	1		-	-	-	-	£45.00	-
H1121	1.1/2	1		-	-	-	-	£55.00	-
H158	1.5/8	1		-	-	-	-	£52.00	-
H134	1.3/4	1.1/2		-	-	-	-	£59.00	-
H178	1.7/8	1.1/2		-	-	-	-	£61.00	-
H2	2	1		-	-	-	-	£61.00	-



All prices exclusive of VAT

Telephone: 01255 220123 Fax: 01255 221422

## TCT Double Flute Metric with Centre Point

Order Ref. No.	Dmm	Lmm	OLmm	6mm	Shank						
					1/4"	8mm	3/8"	10mm	12mm	1/2"	
M265	2	6.5		£19.00	£16.00	£17.00	-	-	-	-	-
M258	2.5	8		£17.00	£19.00	-	-	-	-	-	-
M310*	3	10		£17.00	£17.00	£17.00	-	-	£20.00	-	-
M310/70	3	10	70	-	-	£22.00	-	-	-	-	-
M3411	3.4	11		£15.00	-	-	-	-	-	-	-
M410*	4	10		£17.00	£15.00	£15.00	£16.00	£20.00	£21.00	£15.00	-
M410/70	4	10	70	-	-	£22.00	-	-	-	-	-
M416	4	16	57	£15.00	-	-	-	-	-	-	-
M4511	4.5	11		£16.00	-	-	-	-	-	-	-
M516*	5	16		£18.00	£18.00	£18.00	£18.00	£19.00	£22.00	£22.00	-
M516/70	5	16	70	-	-	£24.00	-	-	-	-	-
M520	5	20	57	£19.00	-	£19.00	-	£19.00	-	-	-
M5520	5.5	20		£18.00	-	-	-	-	-	-	-
M616*	6	16		£18.00	£18.00	£18.00	£19.00	£20.00	£21.00	£21.00	-
M616/70	6	16	70	-	-	£25.00	-	-	-	-	-
M623	6	23	57	£19.00	-	£19.00	-	£21.00	-	-	-
M625*	6	25		-	-	-	-	-	-	£22.00	-
M6316	6.3	16		£16.00	-	£21.00	-	-	-	-	-
M6319	6.3	19		£16.00	-	-	-	-	-	-	-
M6325	6.3	25		£17.00	-	-	-	-	-	-	-
M6525	6.5	25		£19.00	-	-	-	-	-	-	-
M716*	7	16		£18.00	£18.00	£18.00	£18.00	£22.00	-	£25.00	-
M725	7	25		£19.00	-	£19.00	-	-	-	£25.00	-
M7520	7.5	20		£18.00	-	-	-	-	-	-	-
M7925 ~	7.9	25	70	£18.00	£18.00	-	-	-	-	-	-
M820	8	20		£19.00	£19.00	£19.00	£19.00	£24.00	£24.00	£24.00	-
M825	8	25		£20.00	£24.00	-	-	-	-	£22.00	-
M825L ~	8	25	70	£18.00	£18.00	-	-	-	-	-	-
M8125 ~	8.1	25	70	£18.00	£18.00	-	-	-	-	-	-
M8.520	8.5	20		£21.00	-	-	-	-	-	-	-
M8925 ~	8.9	25	70	£18.00	£18.00	-	-	-	-	-	-
M920	9	20		£20.00	£20.00	£20.00	£18.00	£25.00	-	£19.00	-
M925	9	25		-	-	-	-	-	-	£22.00	-
M1015	10	15		£20.00	-	-	-	-	-	-	-
M1020	10	20		£19.00	£19.00	£19.00	£19.00	-	-	-	-
M1025	10	25		£24.00	£24.00	£24.00	£24.00	-	-	£24.00	-
M1030	10	30		-	-	£29.00	£29.00	£29.00	£29.00	-	-
M1035	10	35		-	-	£29.00	-	£28.00	£28.00	-	-
M1125	11	25		£20.00	£20.00	£22.00	£20.00	£23.00	-	£23.00	-
M1220	12	20		£20.00	£20.00	£20.00	£20.00	-	-	£20.00	-
M1225	12	25		£24.00	-	£24.00	£24.00	£24.00	£24.00	-	-
M1230	12	30		-	-	£26.00	£26.00	-	£26.00	£26.00	-
M1240	12	40		-	-	£28.00	£28.00	£28.00	£28.00	£22.00	-
M1250	12	50		-	-	£29.00	£29.00	£29.00	£29.00	-	-
M1250L	12	50	109	-	-	-	-	£29.00	£29.00	-	-
M1254	12	54	115	-	-	-	-	-	-	£30.00	-
M1265	12	65	115	-	-	-	-	-	-	£32.00	-
M12551	12.55	25.4		£22.00	-	-	-	-	-	-	-
M12750	12.7	50		-	-	-	-	£25.00	-	-	-
M1320	13	20		£23.00	£23.00	£23.00	£23.00	-	-	-	-
M1325	13	25		£29.00	£29.00	£29.00	£29.00	£29.00	£29.00	£29.00	-
M1420	14	20		£22.00	£22.00	£22.00	£22.00	-	-	-	-
M1425	14	25		£23.00	-	£23.00	£23.00	-	£23.00	-	-
M1435	14	35		-	-	£30.00	-	-	-	£30.00	-
M1450	14	50		-	-	-	-	£42.00	£42.00	-	-
M1520	15	20		£24.00	£24.00	£24.00	£24.00	-	-	-	-
M1525	15	25		£31.00	£31.00	£31.00	£31.00	-	£31.00	-	-
M1535	15	35		-	-	£31.00	-	-	-	£31.00	-
M1545	15	45		-	-	£32.00	-	-	-	£32.00	-
M1620	16	20		£23.00	-	£23.00	-	-	-	-	-
M1625	16	25		-	-	£29.00	£29.00	-	£29.00	-	-
M1635	16	35		-	-	£30.00	-	£30.00	-	-	-
M1720	17	20		£26.00	£26.00	£26.00	£26.00	-	-	-	-
M1725	17	25		£28.00	-	£28.00	£28.00	-	£28.00	-	-
M1825	18	25		£28.00	£28.00	£28.00	£28.00	-	£28.00	-	-

## Metric - TCT

Order Ref. No.	Dmm	Lmm	OLmm	6mm	Shank						
					1/4"	8mm	3/8"	10mm	12mm	1/2"	
M1835	18	35		-	-	£34.00	£34.00	-	£34.00	£34.00	-
M1850	18	50		-	-	-	-	£39.00	£39.00	£39.00	-
M18220	18.2	20	53	£22.00	£22.00	£24.00	£24.00	-	-	-	-
M18232	18.2	32		-	-	-	£35.00	-	-	£35.00	-
M1925	19	25	67	-	-	-	-	£27.00	-	£27.00	-
M2020	20	20	53	£28.00	£28.00	£28.00	-	-	-	-	-
M2025	20	25		-	£30.00	£30.00	£30.00	£30.00	-	£30.00	-
M2035	20	35		-	-	£35.00	£35.00	-	-	£35.00	-
M2120	21	20		-	£31.00	£31.00	-	-	-	£31.00	-
M2225	22	25		-	£23.00	£23.00	£23.00	£23.00	-	£23.00	-
M2240	22	40	82	-	-	-	-	-	£45.00	£45.00	-
M2325	23	25		-	£31.00	-	-	-	-	£31.00	-
M2420	24	20	53	-	£30.00	£30.00	-	-	-	-	-
M2425	24	25		-	-	-	-	£32.00	£32.00	£32.00	-
M2425/90	24	25	90	-	-	-	-	-	£49.00	-	-
M2520	25	20	53	-	£31.00	£31.00	-	-	-	-	-
M2525	25	25		-	£31.00	£31.00	£31.00	£31.00	£31.00	£31.00	-
M2550	25	50		-	-	-	-	-	-	£55.00	-
M2625	26	25		-	-	-	-	£43.00	£43.00	£43.00	-
M2640	26	40	82	-	-	-	-	-	£53.00	-	-
M2725	27	25		-	-	-	-	-	£43.00	£43.00	-
M2825	28	25	67	-	-	-	-	-	-	£44.00	-
M3025	30	25		-	-	-	£45.00	£45.00	£45.00	£45.00	-
M3525	35	25		-	-	-	£48.00	-	£48.00	£48.00	-
M4015	40	15	57	-	-	-	-	-	£48.00	-	-
M4025	40	25	67	-	-	-	-	-	-	£57.00	-
M5025	50	25	67	-	-	-	-	-	-	£59.00	-

## TCT Double Flute without Centre Point

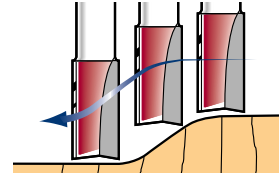
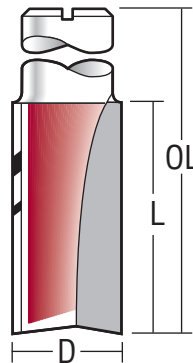

PH58

n.max  
24,000



For profiling only, a range of low cost cutters for heavy duty work which does not require plunging into work piece.

**We strongly recommend using tools with centre points on plunging work.**

The PH Range of cutters can plunge into materials, providing the cutter is ramped in.

Order Ref. No.	D"	L"	OLmm	Shank	
				1/4"	1/2"
PH1412	1/4	1		£17.00	-
PH14	1/4	3/4		£17.00	-
PH141	1/4	1	52	£18.00	-
PH14L	1/4	1	60	£18.00	-
PH516	5/16	3/4		-	£18.00
PH5161	5/16	1		£18.00	-
PH38	3/8	3/4		-	£19.00
PH381	3/8	1		£19.00	£19.00
PH1250	12mm	50mm		-	£27.00
PH121	1/2	1		£17.00	£17.00
PH12	1/2	1.1/4		-	£18.00
PH12L	1/2	1.1/4	102	-	£18.00
PH122	1/2	2		-	£25.00
PH12212	1/2	2.1/2		-	£32.00
PH5834	5/8	3/4		£19.00	-
PH58	5/8	1.1/4		-	£20.00
PH2332	23/32	1.1/4		-	£22.00
PH3434	3/4	3/4		£22.00	-
PH34	3/4	1.1/4		-	£23.00
PH1316	13/16	3/4		£24.00	-
PH112	1	1.1/2		-	£27.00

## HSS Double Flute Straight

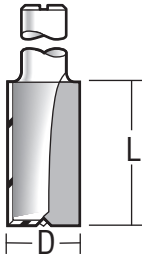

A comprehensive range of high speed steel double flute router cutters all with plunging facility. The keen sharp edge on these cutters makes them ideal for routing softwoods and non-abrasive materials where surface finish is more important over longevity of wear.

P381

n.max  
24,000



BG-TEST  
145-002

### HSS – Imperial Double Flute

Order Ref. No.	D"	L"	1/4"	Shank	
				3/8"	1/2"
P141	1/4	1	£20.00	£20.00	–
P381	3/8	1	£20.00	£20.00	–
H3814	3/8	1.1/4	–	–	£21.00
P12	1/2	3/4	£20.00	–	–
H12	1/2	1.1/4	–	£21.00	£21.00
H1212	1/2	1.1/2	–	–	£23.00
P58	5/8	3/4	£20.00	–	–
H58	5/8	1.1/4	–	£24.00	£24.00
P341	3/4	1	£22.00	£22.00	–
P78	7/8	3/4	£29.00	–	–
H78	7/8	1.1/4	–	£30.00	–
P134	1	3/4	£31.00	–	–
P1	1	1	–	£33.00	–

### HSS – Metric Double Flute

Order Ref. No.	Dmm	Lmm	1/4"	Shank	
				3/8"	1/2"
M516	5	16	£21.00	–	–
M616	6	16	£21.00	–	–
M6316	6.3	16	£21.00	£28.00	–
M716	7	16	£22.00	–	–
M820	8	20	£22.00	£25.00	–
M920	9	20	£22.00	£25.00	–
M1020	10	20	£22.00	–	–
M1035	10	35	–	£25.00	–
M1125	11	25	£22.00	–	–
M1220	12	20	£22.00	–	–
M1320	13	20	£25.00	–	–
M1725	17	25	£25.00	–	£25.00
M18220	18.2	20	£25.00	–	–
M18232	18.2	32	–	–	£26.00
M1925	19	25	–	–	£34.00
M2025	20	25	–	£28.00	–

## TCT Double Flute Left Hand

A range of left hand rotation, left hand cutting tungsten carbide tip double flute straight router cutters with a T.C centre point for plunging. Other sizes can be manufactured to order.

Order Ref. No.	Dmm	Lmm	OLmm	Shank 1/2"
M625LH	6	25	67	£40.00
M1025LH	10	25	67	£40.00
M1225LH	12	25	67	£40.00
H1212LH	12.7	37	83	£45.00
H122LH	12.7	50	99	£50.00
M1625LH	16	25	67	£52.00
M1825LH	18	25	67	£52.00
M1850LH	18	50	95	£60.00

## Single Flute Straight

A range of small diameter single flute cutters for fast free cutting of apertures and shaping work. The single flute provides greater strength and extra clearance.

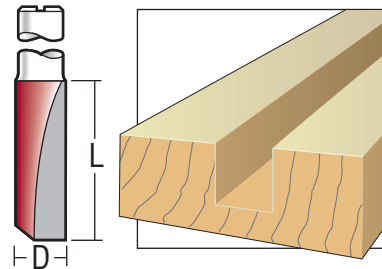

P14SF

n.max  
24,000



\* = SC insert.  
∅ = SC

### TCT – Metric Single Flute

Order Ref. No.	Dmm	Lmm	Shank			
			1/4"	8mm	3/8"	1/2"
M13SF	1	3	£15.00	£15.00	–	–
M156SF	1.5	6	£17.00	–	–	–
M186SF	1.8	6	£17.00	–	–	–
M25SF *	2	5	£17.00	–	–	–
M2510SF *	2.5	10	£18.00	–	–	–
M278SF	2.7	8	£19.00	–	–	–
M310SF *	3	10	£19.00	£19.00	–	–
M410SF *	4	10	£19.00	–	£19.00	–
M516SF *	5	16	£19.00	–	£19.00	£19.00
M520SF *	5	20	£24.00	–	£24.00	–
M616SF *	6	16	£23.00	–	£23.00	–
M620SF	6	20	£24.00	–	–	–
M720SF	7	20	£25.00	–	–	–

### HSS – Metric Single Flute

Order Ref. No.	Dmm	Lmm	Shank 1/4"
M25SF	2	5	£20.00
M410SF	4	10	£20.00

### TCT – Imperial Single Flute

Order Ref. No.	D"	L"	Shank		
			1/4"	3/8"	1/2"
P18SF *	1/8	3/8	£19.00	£19.00	–
H18SF *	1/8	3/8	–	–	£19.00
P316SF *	3/16	1/2	£19.00	£19.00	–
H316SF *	3/16	1/2	–	–	£23.00
H31634SF *	3/16	3/4	–	–	£29.00
P732SF *	7/32	3/4	£25.00	£25.00	–
P1412SF	1/4	1/2	£19.00	–	–
P14SF	1/4	3/4	£23.00	£23.00	–
P141SF	1/4	1	£23.00	–	–
S1438SF ∅	1/4	3/8	£27.00	–	–
S1434SF ∅	1/4	3/4	£29.00	–	–
H516SF	5/16	3/4	£21.00	–	£21.00
H5161SF	5/16	1	–	–	£25.00
H38SF *	3/8	3/4	–	–	£21.00
H381SF	3/8	1	–	–	£25.00
H12SF	1/2	1.1/4	–	–	£23.00
H1212SF	1/2	1.1/2	–	–	£23.00
H122SF	1/2	2	–	–	£32.00
H58SF	5/8	1.1/4	–	–	£32.00

### HSS – Imperial Single Flute

Order Ref. No.	D"	L"	Shank 1/4"
P188SF	1/8	3/8	£20.00
P188LSF	1/8	3/8	£20.00
P1811SF	1/8	7/16	£20.00
P1811LSF	1/8	7/16	£20.00
P316SF	3/16	1/2	£20.00
P316LSF	3/16	1/2	£20.00
P31619SF	3/16	3/4	£20.00
P31619LSF	3/16	3/4	£20.00
P732SF	7/16	3/4	£20.00
P14SF	1/4	3/4	£20.00
P14LSF	1/4	3/4	£20.00

## TCT Long Reach with centre point

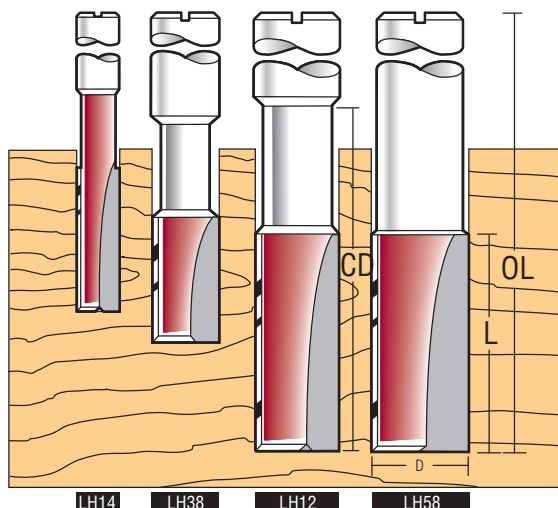

LH Range

n.max  
24,000



BG-TEST  
145-002

Ideal for producing and edging work. Special relief on the cutter body allows for deep slotting work. LH58L2 not to be used in a portable router.

### Imperial Double Flute

Order Ref. No.	D"	L"	Cut depth CD"	OLmm	Shank			
					1/4"	8mm	3/8"	1/2"
LH14	1/4	3/4	1.1/2	70	£22.00	-	-	-
LH14L	1/4	3/4	2	83	£23.00	-	-	-
LH516	5/16	3/4	1.1/2	70	£19.00	-	-	-
LH38	3/8	3/4	2	83	-	£24.00	£24.00	-
LH10	10mm	20mm	50mm	90	-	-	£24.00	-
LH716	7/16	1	2	83	-	-	£23.00	£26.00
LH12	1/2	1.1/4	2	96	-	-	-	£24.00
LH12L	1/2	1.1/4	2.1/2	105	-	-	-	£27.00
LH58	5/8	1.1/4	2	96	-	-	-	£29.00
LH58L	5/8	1.1/4	3	121	-	-	-	£30.00
LH58L2	5/8	2"	6	194	-	-	-	£42.00
LH34	3/4	1.1/4	2	93	-	-	-	£34.00
LH34L	3/4	1.1/4	3	121	-	-	-	£42.00

### Imperial Single Flute

Order Ref. No.	D"	L"	Cut depth CD"	OLmm	Shank		
					1/4"	3/8"	1/2"
LH14SF	1/4	3/4	1.1/2	70	£23.00	-	-
LH516SF	5/16	3/4	1.1/2	70	-	£23.00	-
LH38SF	3/8	3/4	2	83	-	£24.00	-

### Metric Double Flute

Order Ref. No.	D mm	L mm	OLmm	Shank	
				6mm	8mm
M820/70	8	20	70	£24.00	£24.00
M825/70	8	25	70	-	£25.00
M830/90	8	30	90	-	£29.00
M1020/70	10	20	70	£26.00	£26.00
M1030/90	10	30	90	-	£30.00
M1120/70	11	20	70	-	£28.00
M1220/70	12	20	70	£27.00	£28.00
M1230/90	12	30	90	-	£31.00
M1320/70	13	20	70	-	£30.00
M1420/70	14	20	70	£29.00	£29.00
M1430/90	14	30	90	-	£33.00
M1520/70	15	20	70	-	£31.00
M1530/90	15	30	90	-	£36.00
M1620/70	16	20	70	£30.00	£30.00
M1630/90	16	30	90	-	£36.00
M1820/70	18	20	70	£30.00	£30.00
M1830/90	18	30	90	-	£36.00
M1920/70	19	20	70	-	£33.00
M2020/70	20	20	70	-	£34.00
M2215/70	22	15	70	-	£40.00
M2415/70	24	20	70	-	£40.00
M2515/70	25	20	70	-	£42.00
M2815/70	28	20	70	-	£48.00
M3015/70	30	20	70	-	£50.00

## TCT S10 Range with centre point

A special type of cutter designed to match in size the PH & H Range, for machining of hard chipboards and formicas. S Type is our reference for cutters required to withstand high impact and stresses not normally applicable to router work, i.e. mass production speaker holes, flooring, cutting pipeholes and panel profiling.

High wear resistance for MDF.

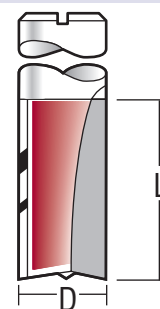

H38

n.max  
24,000



Order Ref. No.	D"	L"	Shank 1/2"
H38 (S10)	3/8	3/4	£24.00
H12 (S10)	1/2	1.1/4	£21.00
PH12 (S10)	1/2	1.1/4	£21.00
H58 (S10)	5/8	1.1/4	£24.00
H34 (S10)	3/4	1.1/4	£29.00
M1025 (S10)	10mm	25mm	£25.00
M1225 (S10)	12mm	25mm	£25.00
M1230 (S10)	12mm	30mm	£27.00

## White Lining

For decorative inlay work for insertion of brass, sycamore and other materials to give a distinctive finish to table tops and period furniture.

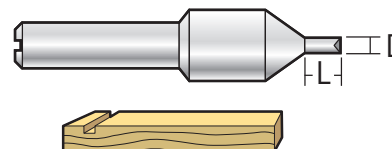

TCT WLC16 & WLC16S has solid insert.

WLC16

n.max  
24,000



### TCT

Order Ref. No.	D"	Lmm	1/4"	Shank 3/8"	1/2"
WLC16	1/16	5	£22.00	£22.00	£22.00
WLC16S	1/16	3	£22.00	-	£22.00

### HSS

Order Ref. No.	D"	Lmm	Shank 1/4"
WLC16	1/16	5	£20.00

## TCT Shear Cut for plywoods and veneers

Shear action downcut to reduce breakout. For short production runs only. For longer life and improved performance see our Solid Carbide Spiral Range. \*These tools are designed to give a 'tear free' groove in conjunction with a tight housed joint when using plywood.

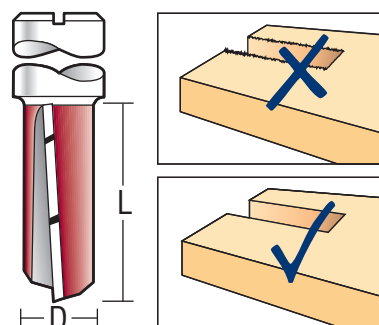

H381S

n.max  
24,000

Order Ref. No.	To suit	D"	L"	Shear Angle	1/4"	Shank 8mm	1/2"
H381S	-	3/8	1	1.5°	£21.00	£21.00	£23.00
H1212S	-	1/2	1.1/2	2.5°	-	-	£31.00
H122S	-	1/2	2	2.5°	-	-	£33.00
H1564S *	1/4 ply	15/64	5/8	1.5°	£23.00	-	£23.00
H3164S *	1/2 ply	31/64	3/4	2.5°	£24.00	-	£24.00
H2332S *	3/4 ply	23/32	3/4	4°	£30.00	-	£30.00

## TCT 2° Tapered Straight

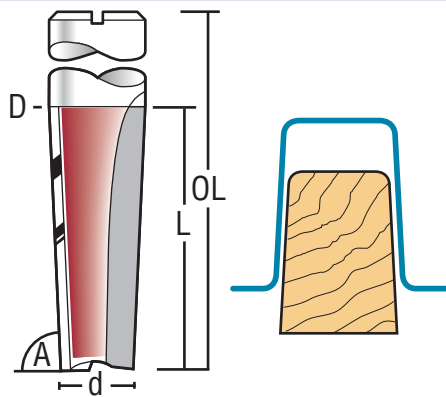

H12T

n. max  
24,000

Two flute cutters with taper designed for constructing vacuum forming moulds. 2° tapered side allows easier release. H58212T can produce a leading edge on a door.

Order Ref. No.	Dmm	Lmm	A	OLmm	dmm	Shank 1/2"
H12T	12.7	32	88°	80	10.5	£30.00
H58212T	16	63	88°	110	11.6	£55.00

## TCT Up/Down Shear Tooth

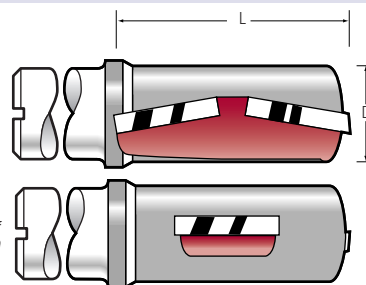

STCS1230

n. max  
24,000

Reverse of STCS1230

Superb high performance cutter with single flute feed rates but double flute balance of cut. Shear action of the STCS gives a good finish top and bottom.

Order Ref. No.	Dmm	Lmm	OLmm	Shank	
				12mm	1/2"
STCS1230	12.7	30	85	–	£42.00
STCS12	12.7	50	104	–	£48.00
STCS14	14	50	104	£46.00	–
STCS58	16	50	104	£48.00	£48.00

## TCT Stagger Tooth

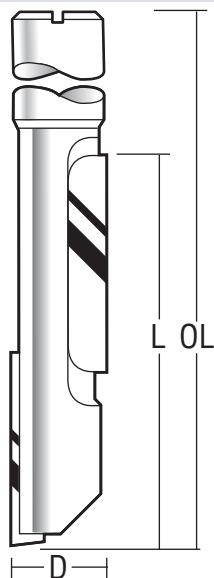

STC12

n. max  
24,000



BG-TEST  
145-002

Superb high performance cutter with single flute feed rates but double flute balance of cut.

Order Ref. No.	Dmm	Lmm	OLmm	Shank 12mm	Shank 1/2"
STC12	12.7	50	104	£42.00	£42.00
STC58	16	50	104	£46.00	£46.00

### Titman Tip

See pages 98 and 131 for other Caravan Manufacturers Cutters.

### CONVERSION

IMPERIAL	METRIC	IMPERIAL	METRIC	IMPERIAL	METRIC
1/16	1.6	3/8	9.5	3/4	19.05
1/8	3.2	1/2	12.7	7/8	22.22
1/4	6.35	5/8	15.88	1	25.4

## TCT Up/Down Shear

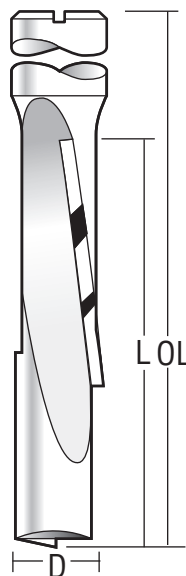

H1212UD

n. max  
24,000



BG-TEST  
145-002

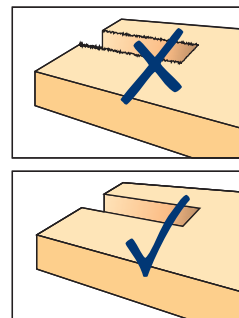

A fine finish may be achieved for trimming veneered and double-faced boards, plywoods and natural timbers using these up-down two flute cutters.

Order Ref. No.	Dmm	Lmm	Overall Length mm	Shank 12mm	Shank 1/2"
H1212UD	12.7	38.1	79	–	£36.00
H122UD	12.7	54	108	£40.00	£40.00

## STC Ball-End Upcut Spiral

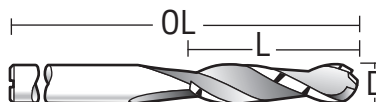

SGC3

n. max  
24,000



The perfect cutter for 3D carving on CNC machines offering a superior finish on the material.

Order Ref. No.	Dmm	Lmm	OLmm	Shank	
				3mm	6mm
SGC3-25	3	25	65	£39.00	–
SGC6-25	6	25	75	–	£55.00

## STC Two Flute • Acrylic – Helical Flute

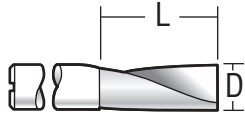

AC14

n. max  
24,000



The accepted solid carbide cutter for machining and routing acrylics, plastics and perspex. The helical cut gives a much easier lead into the material preventing snatching and chipping on cut. Perfect preparation before flame polishing of Perspex. Downcut for chip-free finish on MFC. DC denotes downcut. \* For use on very fine acrylics where downward cutting action will prevent vibration and component lifting. Use a P.T.F.E. spray to enhance performance and prevent waste from welding to the tool.

### STC - Upcut

Order Ref. No.	Dmm	Lmm	3mm	6mm	1/4"	8mm	Shank		
							3/8"	10mm	
AC1.5	1.5	6	£21.00	-	-	-	-	-	-
AC2	2	8	£21.00	-	-	-	-	-	-
AC2.5	2.5	10	£21.00	-	-	-	-	-	-
AC3-6	3	6	-	-	£33.00	-	-	-	-
AC3	3	12	£21.00	£33.00	£33.00	-	-	-	-
AC325	3	25	£39.00	-	-	-	-	-	-
AC4-8	4	8	-	-	£33.00	-	-	-	-
AC4	4	10	-	£33.00	-	-	-	-	-
AC4	4	14	-	-	£33.00	-	-	-	-
AC5-12	5	12	-	-	£33.00	-	-	-	-
AC5	5	19	-	£33.00	£33.00	-	-	-	-
AC6	6	19	-	£33.00	£33.00	-	-	-	-
AC1412	6.35	12.7	-	-	£24.00	-	-	-	-
AC14	6.35	19	-	-	£33.00	-	-	-	-
AC141	6.35	25	-	-	£33.00	-	-	-	-
AC8	8	25	-	-	-	£41.00	-	-	-
AC38	9.5	25	-	-	-	-	£45.00	-	-
AC10	10	25	-	-	-	-	-	£48.00	-

### STC - Downcut

Order Ref. No.	Dmm	Lmm	3mm	6mm	1/4"	8mm	Shank		
							3/8"	10mm	
AC1.5DC*	1.5	5	£21.00	-	-	-	-	-	-
AC2DC*	2	6	£21.00	-	-	-	-	-	-
AC2.5DC*	2.5	7	£21.00	-	-	-	-	-	-
AC3-6DC	3	6	-	-	£33.00	-	-	-	-
AC3DC*	3	12	£21.00	£33.00	£33.00	-	-	-	-
AC325DC	3	25	£39.00	-	-	-	-	-	-
AC4-8DC	4	8	-	-	£33.00	-	-	-	-
AC4DC*	4	14	-	£33.00	£33.00	-	-	-	-
AC5-12DC	5	12	-	-	£33.00	-	-	-	-
AC5DC*	5	19	-	£33.00	£33.00	-	-	-	-
AC6DC*	6	19	-	£33.00	£33.00	-	-	-	-
AC14DC*	6.3	19	-	-	£33.00	-	-	-	-
AC141DC	6.35	25	-	-	£33.00	-	-	-	-
AC8DC*	8	25	-	-	-	£41.00	-	-	-
AC38DC*	9.5	25	-	-	-	-	£48.00	-	-
AC10DC	10	25	-	-	-	-	-	£54.00	-

### HSS

Order Ref. No.	Dmm	Lmm	Shank 1/4"
AC14	6.35	19	£25.00

### Titman Tip

AC Cutters can be modified at Titman's to allow shorter cut lengths when cutting thin acrylic, contact sales.

## STC Single Flute • Acrylic – Helical Flute



AC3-6SF

n. max  
24,000



These tools are designed to give a smooth finish on hard plastics.

### Upcut

Order Ref. No.	Dmm	LOC mm	Shank			
			6mm	1/4"	8mm	10mm
AC3-6SF	3	6	£29.00	£29.00	-	-
AC3-12SF	3	12	£29.00	£29.00	-	-
AC4-8SF	4	8	£29.00	£29.00	-	-
AC4-12SF	4	12	£29.00	£29.00	-	-
AC5-12SF	5	12	£29.00	£29.00	-	-
AC6-12SF	6	12	£32.00	£32.00	-	-
AC6-20SF	6	20	£32.00	£32.00	-	-
AC8-25SF	8	25	-	-	£33.00	-
AC10-25SF	10	25	-	-	-	£44.00

### Downcut

Order Ref. No.	Dmm	LOC mm	Shank			
			6mm	1/4"	8mm	10mm
AC3-6DCSF	3	6	£29.00	£29.00	-	-
AC3-12DCSF	3	12	£29.00	£29.00	-	-
AC4-8DCSF	4	8	£29.00	£29.00	-	-
AC4-12DCSF	4	12	£29.00	£29.00	-	-
AC5-12DCSF	5	12	£29.00	£29.00	-	-
AC6-12DCSF	6	12	£32.00	£32.00	-	-
AC6-20DCSF	6	20	£32.00	£32.00	-	-
AC8-25DCSF	8	25	-	-	£33.00	-
AC10-25DCSF	10	25	-	-	-	£44.00

## STC for 'low melting point' plastics

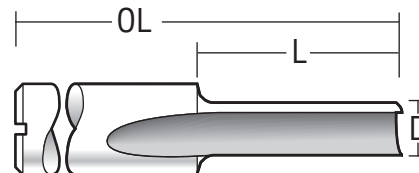

AS18

n. max  
24,000



**Single Flute Solid Carbide** for low melting point plastics. Use shortest cut lengths possible. Radius flute gives effective cutting on ductile plastics. Special flute design allows for smooth feed rate and efficient chip clearance. An ideal tool for cutting ABS components on 5 & 7 axis machines.

Order Ref. No.	D	L	OLmm	6mm	Shank 1/4"	8mm	3/8"	10mm	12mm	1/2"
AS3	3mm	10mm	50	£21.00	-	-	-	-	-	-
AS18	1/8"	1/2"	50	£21.00	-	-	-	-	-	-
AS4	4mm	12mm	52	£21.00	-	-	-	-	-	-
AS316	3/16"	5/8"	50	£23.00	-	-	-	-	-	-
AS5	5mm	16mm	56	£23.00	-	-	-	-	-	-
AS6	6mm	19mm	59	£23.00	-	-	-	-	-	-
AS14	1/4"	3/4"	63	£24.00	-	-	-	-	-	-
AS141	1/4"	1"	63	£24.00	-	-	-	-	-	-
AS516	5/16"	3/4"	63	-	-	-	£34.00	-	-	-
AS8	8mm	25mm	65	-	-	£34.00	-	-	-	-
AS38	3/8"	7/8"	63	-	-	-	£35.00	-	-	-
AS10	10mm	25mm	65	-	-	-	-	£35.00	-	-
AS12	12mm	25mm	70	-	-	-	-	-	£59.00	-
AS12	1/2"	1"	75	-	-	-	-	-	-	£63.00

## STC • Perspex

For a good finish on all plastics and acrylics, please ensure that the shank is inserted as far as possible into the collet this helps reduce vibration which causes a reduction in the quality of finish.

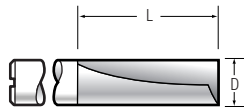

ACR141

n.max  
24,000



**ACR121** - For tufnol and extra fine finish on MDF. Cutters required for cutting perspex or similar acrylic materials can be selected from our standard range in terms of cutter size. When ordering, state standard cutter reference, thickness of material being cut, colour and grade. The tool will then be supplied to the special angle necessary for efficient machining.  $\varnothing$  = Solid Carbide

See page 126-131 for larger diameter solid spiral cutters

### Double Flute

Order Ref. No.	D	L	Shank					
			6mm	1/4"	8mm	10mm	12mm	1/2"
ACR6	6mm	20mm	£23.00	-	-	-	-	-
ACR14	1/4"	3/4"	-	£22.00	-	-	-	-
ACR141 $\varnothing$	1/4"	1"	-	£25.00	-	-	-	-
ACR8	8mm	25mm	-	-	£32.00	-	-	-
ACR14	1/4"	3/4"	-	£22.00	-	-	-	-
ACR10	10mm	25mm	-	-	-	£39.00	-	-
ACR12	12mm	25mm	-	-	-	-	£57.00	-
ACR121 $\varnothing$	1/2"	1"	-	-	-	-	-	£60.00

### Single Flute

Order Ref. No.	D	L	Shank	
			1/4"	1/2"
ACR1412SF	1/4"	1/2"	£24.00	-
ACR14SF	1/4"	3/4"	£25.00	-
ACR12SF	1/2"	1.1/4"	-	£27.00

## TCT Double Flute with Internal Threaded Shanks

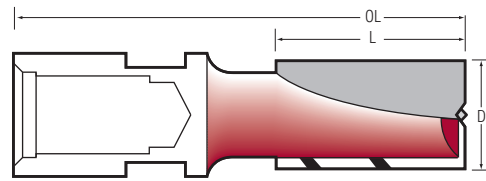

TM1025

n.max  
24,000



BG-TEST  
145-002

All cutters in this group have safe plunging points. The direct location of the internal threaded TM Range offers a more stable and solid location that reduces vibration on cut. Ideal for work on stair strings and cross grain cutting.

Normal internal thread  
M12 x 1 = Elu.  
M10 x 1.5 = Interwood/Scheer.

Please state if required to fit Interwood or ELU machines.

Order Ref. No.	Dmm	Lmm	OLmm	State Shank	Price
TM310	3	10	55	M10/M12	£24.00
TM410	4	10	55	M10/M12	£25.00
TM516	5	16	55	M10/M12	£25.00
TM616	6	16	55	M10/M12	£25.00
TM716	7	16	55	M10/M12	£25.00
TM820	8	20	55	M10/M12	£25.00
TM920	9	20	55	M10/M12	£26.00
TM1025	10	25	58	M10/M12	£31.00
TM1030	10	30	63	M10/M12	£33.00
TM1035	10	35	70	M10/M12	£35.00
TM1125	11	25	58	M10/M12	£31.00
TM1225	12	25	58	M10/M12	£31.00
TM1240	12	40	74	M10/M12	£38.00
TM1245	12	45	80	M10/M12	£38.00
TM1325	13	25	58	M10/M12	£31.00
TM1425	14	25	58	M10/M12	£32.00
TM1435	14	35	70	M10/M12	£36.00
TM1445	14	45	80	M10/M12	£39.00
TM1460	14	60	93	M10/M12	£49.00
TM1525	15	25	58	M10/M12	£33.00
TM1535	15	35	70	M10/M12	£39.00
TM1545	15	45	80	M10/M12	£41.00
TM1625	16	25	58	M10/M12	£34.00
TM1635	16	35	70	M10/M12	£39.00
TM1645	16	45	80	M10/M12	£41.00
TM1660	16	60	95	M10/M12	£61.00
TM1725	17	25	58	M10/M12	£35.00
TM1825	18	25	58	M10/M12	£36.00
TM1835	18	35	70	M10/M12	£40.00
TM1845	18	45	80	M10/M12	£44.00
TM1860	18	60	95	M10/M12	£66.00
TM1925	19	25	58	M10/M12	£38.00
TM2025	20	25	58	M10/M12	£38.00
TM2035	20	35	70	M10/M12	£42.00
TM2045	20	45	80	M10/M12	£67.00
TM2060	20	60	95	M10/M12	£64.00
TM2125	21	25	58	M12	£40.00
TM2225	22	25	58	M10/M12	£40.00
TM2235	22	35	63	M10/M12	£44.00
TM2260	22	60	95	M12	£64.00
TM2325	23	25	55	M10/M12	£41.00
TM2425	24	25	55	M10/M12	£42.00
TM2445	24	45	80	M12	£67.00
TM2525	25	25	55	M10/M12	£43.00
TM2625	26	25	55	M10/M12	£44.00
TM2725	27	25	58	M12	£44.00
TM3025	30	25	55	M10/M12	£48.00
TM3520	35	20	50	M12	£54.00
TM3525	35	25	55	M10/M12	£55.00

## TCT Hinge Recessing & Fire Strip

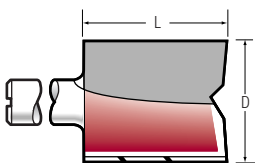

A cutter ideal for hinge recessing or the recessing of the underside of a handrail. HR10 & HR10.5 are designed for the cutting of fire proofing strips.

HR10

n.max  
24,000



Order Ref. No.	D	L	Overall Length	Shank 1/4"
HR10•	10mm	19mm	51mm	£19.00
HR105•	10.5mm	19mm	51mm	£19.00
HR1220L	12mm	20mm	70mm	£21.00
HR12720L	12.7mm	20mm	70mm	£21.00
HR12	1/2	3/4	51mm	£19.00
HR58	5/8	3/4	51mm	£21.00
HR34	3/4	3/4	51mm	£22.00

• Denotes special relieving cutters for intumescent 'fireproof' strip.

Special relief on HR10 & HR10.5 allows for faster feed and cleaner bottom finish. Please note HR1220L and HR12720L have 45mm shank length to suit hinge jig.

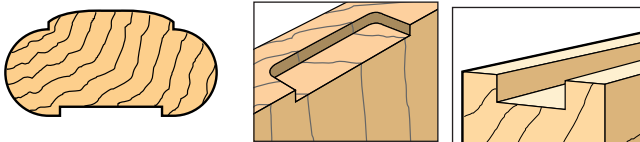

Used in conjunction with a side fence on a portable routing machine. When machining always feed away from the operator, with fence on the right hand side.

## TCT Single Flute Spoon Cutters for eccentric chucks

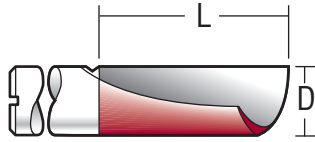

S925

n.max  
24,000



Fixed head machines only – not on portables.

\*Solid carbide insert. Ø Solid carbide

Spoon bits do not require a BG Test No.

Order Ref. No.	Dmm	Lmm	Shank	
			9.5mm	12mm
S39 insert*	3	9	£19.00	–
S315 insert*	3	15	£20.00	–
S3515 insert*	3.5	15	£20.00	–
S49 insert*	4	9	£20.00	–
S415 insert*	4	15	£20.00	–
S4515 insert*	4.5	15	£20.00	–
S59 insert*	5	9	£20.00	–
S515 insert*	5	15	£21.00	–
S5515 insert*	5.5	15	£21.00	–
S618 insert*	6	18	£21.00	–
S622 insert*	6	22	£21.00	–
S6522 insert*	6.5	22	£21.00	–
S725 solid Ø	7	25	£24.00	–
S7525 solid Ø	7.5	25	£24.00	–
S825 solid Ø	8	25	£24.00	–
S8525 solid Ø	8.5	25	£24.00	–
S925 solid Ø	9	25	£24.00	–
S1025 tipped Ø	10	25	£26.00	–
S1225 tipped Ø	12	25	£27.00	–
S1325 tipped Ø	13	25	£27.00	–
S1432 tipped Ø	14	32	£28.00	£28.00
S1532 tipped Ø	15	32	£28.00	£28.00
S1632 tipped Ø	16	32	£28.00	£28.00
S1832 tipped Ø	18	32	£29.00	£29.00

### Spoon Bit Chart *This unique guide will help you to select the correct cutter and the right chuck number.*

Remember the higher angle number - between 30° and 50° - the smaller the cut. For finer adjustments move cutter between the 30° and 50° marks on chuck.

Diameter of Cut Required	Number of Chuck	Titman Cutter Part Number	Angle on Chuck
3.5mm	1	S39/S315	45°
5mm	1.5	S49/S415	45°
6mm	1.5	S59/S515	45°
7.5mm	2	S618/S622	47°
8.5mm	2	S725	46°
9mm	2.5	S725	42°
9.5mm	2	S825	46°
10mm	2.5	S825	42°
10.5mm	3	S825	39°
11.5mm	3	S925	38°
12.5mm	3	S1025	37°
15mm	4	S1225	47°
15.5mm	4	S1225	34°
15.7mm	5	S1432	53°
18mm	5	S1432	43°
18.5mm	5	S1532	52°
19mm	5	S1532	42°
19.5mm	6	S1532	48°
20mm	6	S1532	40°
20.5mm	6	S1632	48°
21mm	6	S1632	39°
23mm	7	S1832	51°
23.5mm	7	S1832	45°
24mm	8	S1832	49°
24.5mm	8	S1832	42°

## TCT Face Milling

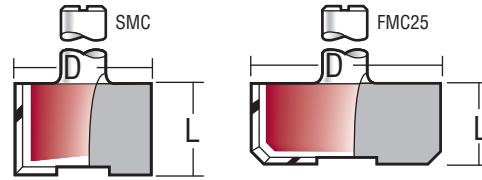

SMC18  
FMC25

n.max  
24,000



BG-TEST  
145-002

For trimming aluminium flashing. **SMC20** has a shear action for finer finish. **SMC20** on 1/2" shank has 22mm cut length. **FMC** has a 3 wing for trepanning large areas. **RT version available - page 138.**

Order Ref. No.	Dmm	Lmm	OLmm	Shank				
				6mm	1/4"	8mm	3/8"	1/2"
SMC18	18	12	44	–	£22.00	£22.00	–	–
SMC20	20	13	45	–	£29.00	£29.00	£29.00	£29.00
FMC25	25	12	44	£42.00	£42.00	£42.00	–	–
FMC35	35	6	40	–	–	£45.00	–	–

## TCT Sinking

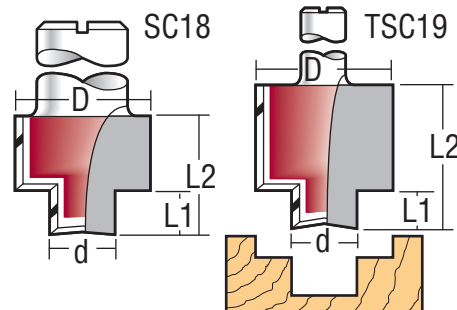

SC18  
TSC19

n.max  
24,000



BG-TEST  
145-002

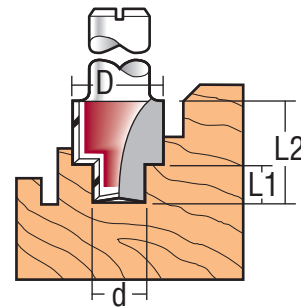

SC16.3

n.max  
24,000



BG-TEST  
145-002

For library and book shelving strip.

Order Ref. No.	Dmm	dmm	L1mm	L2mm	TCT Shank				
					1/4"	8mm	3/8"	12mm	1/2"
SC16	16	12	10	19	£43.00	–	£43.00	–	£43.00
SC163	16.3	12.3	9.5	18	–	£43.00	–	–	–
SC18	18	12	6	16	£43.00	£43.00	£43.00	£43.00	£43.00
SC19	19	13	6	14	£43.00	–	–	–	–
SC20	20	14	6	16	£43.00	£43.00	£43.00	£43.00	£43.00
SC203	20.3	12.3	9.5	18	–	£46.00	–	–	–
SC203/6	20.3	12.3	6	15	–	£46.00	–	–	–
SC22	22	16	6	16	£48.00	£48.00	£48.00	£48.00	£48.00
TSC19	19	9.5	6	19	£48.00	£48.00	£48.00	£48.00	£48.00