

Dovetail & Stairhousing

TCT Stairhousing

Used in overhead routers with stair stringing jigs, (right hand version).

For stair trenching machines cutters are offered in both rotations. Standard angle 5°.

Tufnol stairhousing jigs are available from Titmans.

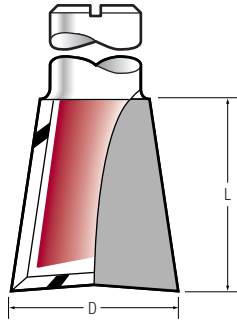

SRC78

n.max
24,000



BG-TEST
145-002

Imperial

Order Ref. No.	D	L	Right Hand		Left Hand	
			3/8"	1/2"	3/8"	1/2"
SRC58	5/8"	1"	£39.00	£39.00	£41.00	£41.00
SRC34	3/4"	1"	£40.00	£40.00	£41.00	£41.00
SRC78	7/8"	1"	£40.00	£40.00	£46.00	£46.00
SRC1	1"	1"	£46.00	£46.00	£50.00	£50.00

Titman Tip Top bearing option available - see item XC116, page 103.

Metric

Order Ref. No.	Dmm	Lmm	A	Right Hand	
				3/8"	1/2"
SRC14LK	14	20	95°	£38.00	£38.00
SRC16LK	16	26	95°	-	£39.00
SRC19LK	19	26	95°	-	£41.00
SRC22LK	22	26	95°	-	£46.00

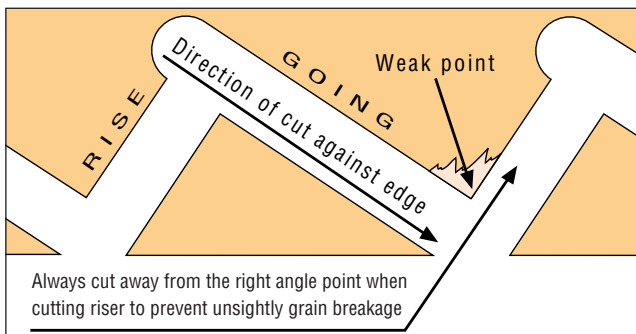

Titman Tip When machining strings ensure the right angle edge does not break off in machining. Cut away from the right angle point.

RT Stairhousing

A range of stairhousing cutters in replacement tip form.

Order Ref. No.	Dmm	Lmm	Right Hand		Left Hand	
			1/2"	1/2"	1/2"	1/2"
SRC19RT	19	20	£99.00		£99.00	
SRC22RT	22	20	£99.00		£99.00	
SRC25RT	25	20	£99.00		£99.00	
Tips			Price each			
SRC-RTLH	Replacement tip left hand		£9.00			
SRC-RTRH	Replacement tip right hand		£9.00			

TCT Dovetail

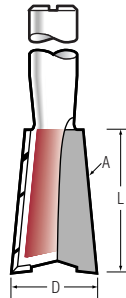

This range of dovetail cutters are for use in conjunction with the Trend Dovetail Jig.

DJC9

n.max
24,000



BG-TEST
145-001

Order Ref. No.	Dmm	Lmm	A	OLmm	Shank	
					1/4"	8mm
DJC7	11.3	19	97°	59	£19.00	£19.00
DJC9	11.3	16	99°	66	£19.00	£19.00
DJC11	11.3	13	101°	63	£20.00	£20.00
DJC14	11.3	9.5	104°	59	£20.00	£20.00
DJC20	11.3	6.35	110°	56	£20.00	£20.00

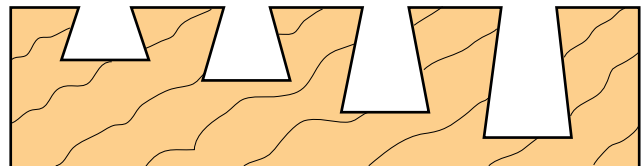

TCT Dovetail straight - two flute

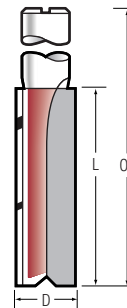

DJCS79

n.max
24,000



BG-TEST
145-002

For use with the Trend Dovetail Jig.

Order Ref. No.	Dmm	Lmm	OLmm	Shank	
				1/4"	8mm
DJCS79	7.9	25	70	£19.00	£19.00
DJCS78	8	25	70	£19.00	£19.00
DJCS81	8.1	25	70	£19.00	£19.00
DJCS89	8.9	25	70	£19.00	£19.00

TCT Dovetail

Standard sizes for all dovetail applications. i.e. slot dovetail, hidden dovetail, etc. Available with scribers on DC127 (1/4" TCT shank only) to enable use in conjunction with portable routing jigs. DC10L has a strengthened neck allowing for deeper dovetail joints.

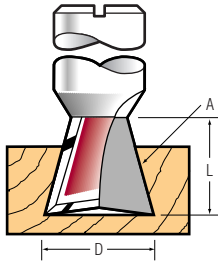

DC14

n.max
24,000



BG-TEST
145-002

DC5 suits our Weatherstrip 205S. See our weatherstrip section.

The WDC Range can be used in the Titman Wedgelok Cutter. See page 169 for the perfect answer for the jointing of angled and butt joints.

Ø Solid Carbide.

Order Ref. No.	Dmm	Lmm	A	Shank					
				6mm	1/4"	8mm	3/8"	12mm	1/2"
DC5 Ø	5	4	15°	£26.00	£26.00	-	-	-	-
WDC1 Ø	5.2	4	18°	£28.00	£28.00	-	-	-	-
DC6 Ø	6	6.9	98°	-	£26.00	-	-	-	-
WDC2 Ø	8	6	18°	£28.00	£28.00	-	-	-	-
DC8	8	7	18°	£28.00	-	-	-	-	-
WDC3 Ø	9.3	7.6	18°	£33.00	£33.00	-	-	-	-
DC95	9.5	8.5	12°	£24.00	£24.00	-	-	-	-
DC10	10	9	10°	£24.00	£24.00	£24.00	£24.00	-	£24.00
DC10L	10	11	10°	-	-	£24.00	£24.00	-	-
DC12	12	10	10°	£24.00	£24.00	£24.00	£24.00	-	£24.00
DC135	13.5	12.5	13°	-	-	£24.00	-	-	-
DC14	14	14	10°	£26.00	£26.00	£26.00	£26.00	-	£26.00
DC16	16	14	10°	-	-	£27.00	£27.00	-	£27.00
DC18	18	15	10°	-	-	£30.00	£30.00	-	£30.00
DC20	20	16	10°	-	-	£30.00	£30.00	-	£30.00
DC22	22	20	15°	-	-	£32.00	£32.00	-	-
DC26	26	25	15°	-	-	-	-	£45.00	-

Ø Solid carbide

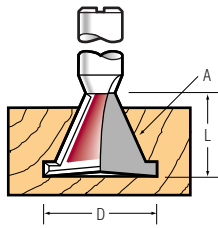

DC127

n.max
24,000



BG-TEST
145-002

Order Ref. No.	Dmm	Lmm	A	Shank		
				6mm	8mm	1/4"
DCS12	12	12.7	13°	£23.00	-	-
DCS127	12.7	12.7	13°	£23.00	-	£23.00
DCS143	14.3	13.5	15°	-	£26.00	-

Brookman Dovetails

Order Ref No		HSS		TCT	
F40 Brookman Range	3/8" BSF threaded shank	£48.00	£36.00		
F41 Brookman Range	3/8" BSF threaded shank	£48.00	£36.00		
F42 Brookman Range	3/8" BSF threaded shank	£48.00	£36.00		
Brookman Range - quantity purchase - price each on 15 quantity		£47.00	£35.00		
Brookman Range - quantity purchase - price each on 25 quantity		£46.00	£34.00		

TCT Dovetail Cutters suits Leigh Dovetail Jig

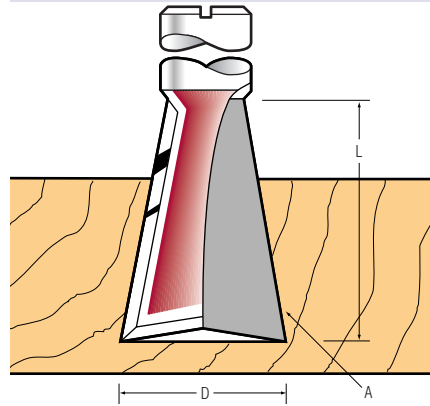

These dovetail cutters are to be used in conjunction with the Leigh Dovetail Jig.

LDC20.5

n.max
24,000



BG-TEST
145-002

Contact Titman's Technical Department for further information.

Order Ref. No.	Leigh Code	D	L	A	Shank		
					1/4"	8mm	1/2"
LDC95	L70	9.5mm	12.7mm	8°	£26.00	-	-
LDC12.7	L120	12.7mm	12.7mm	14°	£26.00	-	-
LDC12L	L80	12.7mm	21mm	8°	£26.00	-	-
LDC175	L90	17.5mm	25mm	8°	-	-	£35.00
LDC205	L100	20.5mm	32mm	8°	-	-	£35.00
L50	L50	1/4"	1/4"	8°	£25.00	-	-
L60	L60	5/16"	3/8"	8°	£26.00	-	-
L101	L101	1/2"	5/8"	10°	£27.00	£27.00	-
L128	L28	1/2"	3/8"	18°	£27.00	£27.00	-

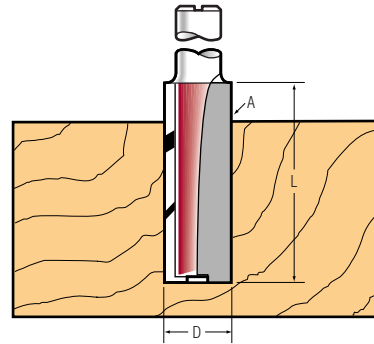

L8, L11, L125
Straight cut for corner box.
(Comb joint)

L8

n.max
24,000



BG-TEST
145-002

Order Ref. No.	Leigh Code	Dmm	Lmm	A	Shank		
					1/4"	8mm	1/2"
L8	L140	8	26	90°	£19.00	-	-
L11	L150	11	31.5	90°	-	-	£19.00
L125	L160	12.7	31.5	90°	-	-	£20.00

TCT Dovetail Cutters

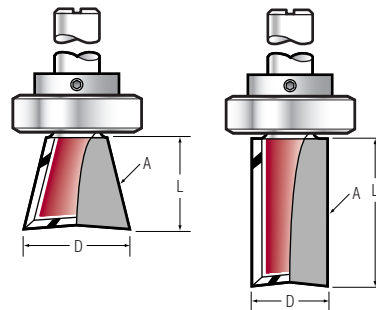

A range of shank mounted bearing cutters for use in the popular dovetail jigs. See page 163 for the Titman Dovetail Jig.

BDC14B
M1020B

n.max
24,000



BG-TEST
145-002

Order Ref. No.	Suits Code	Dmm	Lmm	A	OLmm	Bearing mm	Shank
							1/4"
BDC14B	Bosch ZF60BC	14	12	14°	50	17	£30.00
M1020B	Bosch ZF6010BC	10	20	90°	60	13.8	£30.00
ADC12B	Axminster	15	13	14°		1/2"	£30.00
EDC12B	Elu	15	13	14°		10.8	£30.00
B10.8	Replacement bearing					10.8	£9.00
B127	Replacement bearing					12.7	£6.00
B13.8	Replacement bearing					13.8	£7.00
B17	Replacement bearing					17.00	£7.00