

# Pinecut Range

For softwoods

The most cost effective router cutter for softwoods

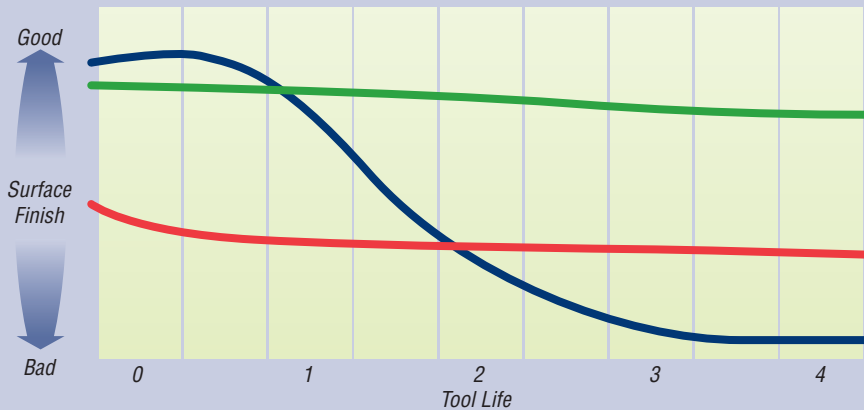

Titman has developed an innovative grade of tungsten carbide, to replace HSS, as the cutting material for softwoods. The new grade enables a sharp cutting edge to be ground, giving a TCT life with a HSS finish. The new grade will out perform other cutting materials on softwoods – HSS cutters in terms of life and standard tungsten carbide cutters in terms of surface finish.

## TCT 'V' Grooving

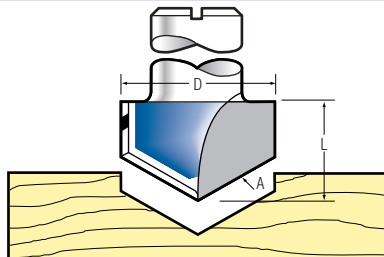

PCVGC60

n.max  
24,000



BG-TEST  
145-001

Order Ref. No.	Dmm	Lmm	A	1/4"	Shank 8mm	1/2"
PCVGC45	18	14	45°	£29.00	£29.00	£29.00
PCVGC60	15.75	16	60°	£27.00	£27.00	£27.00

See pages 25-26 for V-Grooving cutters.

## TCT Chamfering Edge

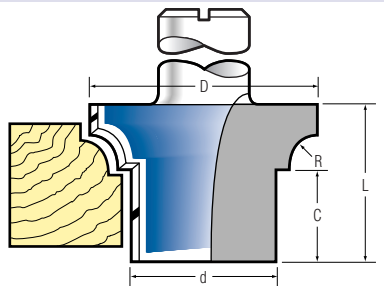

PCBEC4

n.max  
24,000



BG-TEST  
145-001

Order Ref. No.	Dmm	dmm	Lmm	Cmm	R	Shank 1/2"
PCBEC4	30	20	22	12	4	£95.00

See pages 78 for BEC cutters.

## TCT Straight Double Flute with c/point

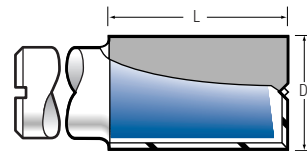

PCH381

n.max  
24,000



BG-TEST  
145-002

Order Ref. No.	D	L	1/4"	Shank 8mm	1/2"
PCH381	3/8"	1"	–	–	£26.00
PCH12	1/2"	1.1/4"	–	–	£23.00
PCH122	1/2"	2"	–	–	£38.00
PCP58	5/8"	3/4"	£28.00	–	–
PCH58	5/8"	1.1/4"	–	–	£31.00
PCH582	5/8"	2"	–	–	£48.00
PCM1020	10mm	20mm	£25.00	£25.00	–
PCM1035	10mm	35mm	–	–	£37.00
PCM1220	12mm	20mm	£28.00	£30.00	–

See page 5-12 for main range of Straights.

## Special Profiles



The Pinecut Range shown only represent a fraction of the styles possible. We can make almost any special you require. Please submit your drawings or profiles to our Sales Department for a fast quote.

Replacement Tip Router cutters are also available with the Pinecut carbide grade.

## TCT Rounding Over with Bearing or Guide Pin

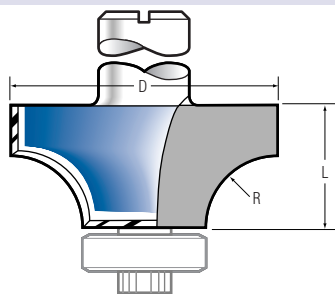

**PCROC14**

n.max  
24,000



BG-TEST  
145-001

Order Ref. No.	Dmm	Rmm	Lmm	1/4"	Shank 8mm	1/2"	
PCROC14	22	6.3	13.5	Guide pin	£45.00	£45.00	
PCROC38	29	9.5	17.5	Guide pin	£48.00	£48.00	
PCROCB63	28	6.3	12.7	Bearing	£45.00	£45.00	
PCROCB95	35	9.5	15.8	Bearing	£47.00	£47.00	
PCROCB127	41	12.7	19	Bearing	£52.00	£52.00	
B127	Replacement Bearing					£6.00	
B16	Replacement Bearing					£7.00	

See page 29 for main range of Rounding Over cutters.

## TCT Corner Ovolo Heavy duty

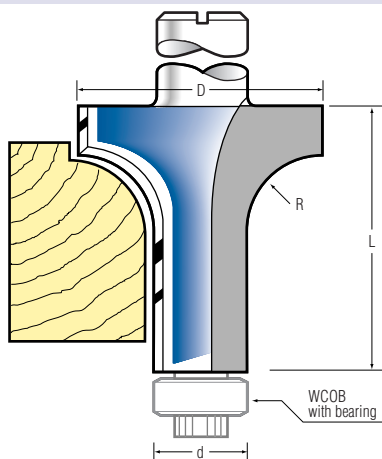

**PCWCO10**

n.max  
24,000



BG-TEST  
145-002

Order Ref. No.	Dmm	Rmm	Lmm	Shank 1/2"
PCWCO10	33	10	36	£80.00
B16	Replacement Bearing			£7.00

See page 30 for all WCO cutters.

## TCT Guttering

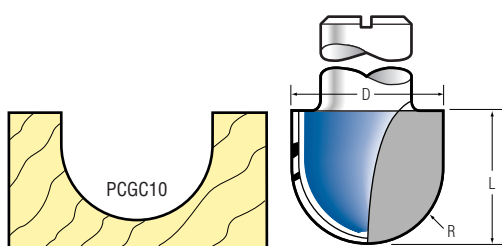

**PCGC10**

n.max  
24,000



BG-TEST  
145-001

Order Ref. No.	Dmm	Rmm	Lmm	1/4"	Shank 8mm	1/2"
PCGC10	20	10	18	£54.00	£54.00	£54.00

See pages 31-32 for all Guttering cutters.

## TCT Half Round 1 flute

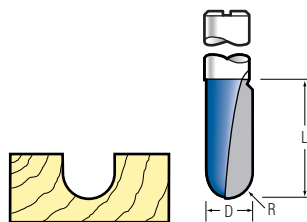

**PCHRC3**

n.max  
24,000



BG-TEST  
145-001

Order Ref. No.	Dmm	Rmm	Lmm	Shank 1/4"	8mm
PCHRC3	6	3	16	£28.00	£28.00
PCHRC5	10	5	18	£30.00	£30.00

See pages 31-32 for all Guttering cutters.

## TCT Bevelled

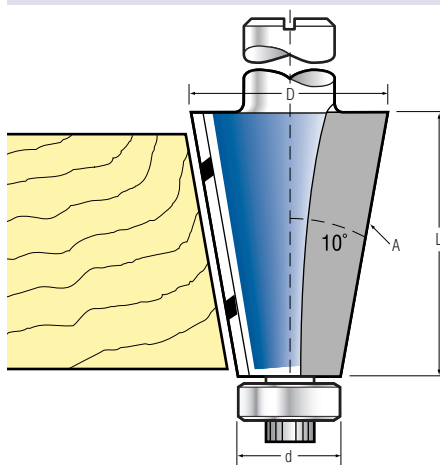

**PCBCB10**

n.max  
24,000



BG-TEST  
145-001

Order Ref. No.	Dmm	dmm	Lmm	A	Shank 8mm	1/2"
PCBCB10	26	12.7	35	10°	£63.00	£63.00
B127	Replacement Bearing				£6.00	

See pages 24-24 for Bevel & Chamfer cutters.

## TCT Bearing Guide

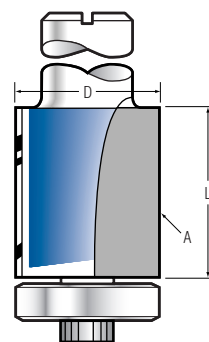

**PCBGT90LK2**

n.max  
24,000



BG-TEST  
145-002

Order Ref. No.	Dmm	Lmm	A	1/4"	Shank 8mm	1/2"
PCBGT90LK2	18	50	90°	-	-	£70.00
PCBGT60	28	12	60°	£42.00	-	-
PCBGT45	27	9	45°	£47.00	£47.00	-
B18	Replacement Bearing					£7.00

See pages 17-19 for Bearing Guided

# Finger Pull Cutters

## TCT Finger Pull

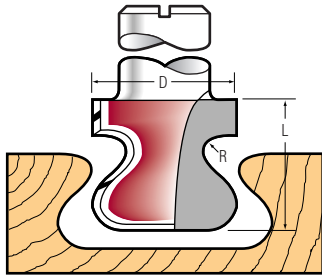

FPC19

n. max  
24,000



BG-TEST  
145-001

For solid handles and pulls on kitchen and wall unit doors, with bottom cut for better finish and plunging.

Order Ref. No.	Dmm	Lmm	Rmm	1/4"	8mm	Shank 3/8"	12mm	1/2"
FPC19	19	19	2	£78.00	£78.00	£78.00	£78.00	£78.00

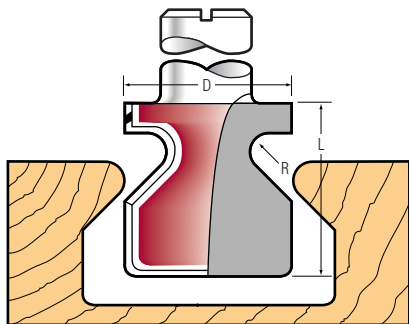

FPC22

n. max  
24,000



BG-TEST  
145-001

A variation of the FPC19 giving a square bottom and undercut.

Order Ref. No.	Dmm	Lmm	Rmm	8mm	Shank 12mm	1/2"
FPC22	22	22	2.5	£85.00	£85.00	£85.00

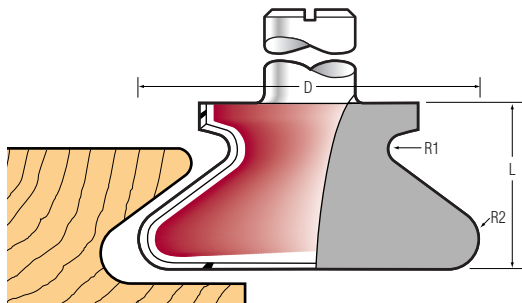

SFPC45

n. max  
18,000



BG-TEST  
145-001

This shallow finger pull cutter has a smaller radius but longer on projection.

Order Ref. No.	Dmm	Lmm	R1mm	R2mm	Undercut Depthmm	Shank 12mm	1/2"
SFPC45	45	22	3	4	12	£85.00	£85.00

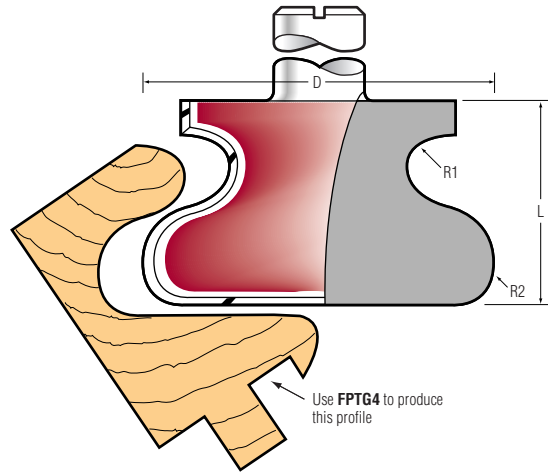

FPC47

n. max  
18,000



BG-TEST  
145-001

Used on its own to produce shallow undercut mouldings or together with FPTG4, see next, for machining of traditional finger pull sections. An inexpensive alternative to complicated profile cutter blocks on a moulding machine.

Order Ref. No.	Dmm	Lmm	R1mm	R2mm	Shank 12mm	1/2"
FPC38	38	23	2	6.3	£89.00	£89.00
FPC47	47	28.7	3.5	6.3	£109.00	£109.00

## TCT Finger Pull & Groover Set

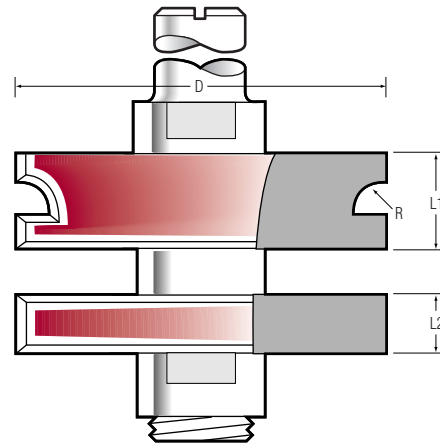

FPTG4

n. max  
18,000



Supplied as a complete set including shaping cutter, 2 groovers, spacer and arbor, the FPTG4 fulfills the need to produce intricate finger pull sections using a router. Use together with FPC47 to complete section.

Fixed head machines only - not on portables.

Order Ref. No.	Dmm	L1mm	L2mm	Rmm	Groover Width mm	Shank 12mm	1/2"
FPTG4	50	13	8	4	6+8	£154.00	£154.00

35

Premier Router Cutters